

# SERVICE CARTS - SCS2-2840

APPROX WEIGHT: 100.27 lbs.  
DOES NOT INCLUDE WEIGHT OF POWER OR PACKAGING!!!

\*\*\* ANY ADDITIONS, DELETIONS, OR OMISSIONS MUST BE CORRECTED ON THIS DRAWING AS THIS DRAWING WILL BE CONSIDERED ALL INCLUSIVE \*\*\*

ALL GRAPHICS PROVIDED ARE FOR REFERENCE ONLY. IF CERTAIN DIMENSIONS ARE CRITICAL PLEASE VERIFY THOSE DIMENSIONS WITH YOUR SALESPERSON

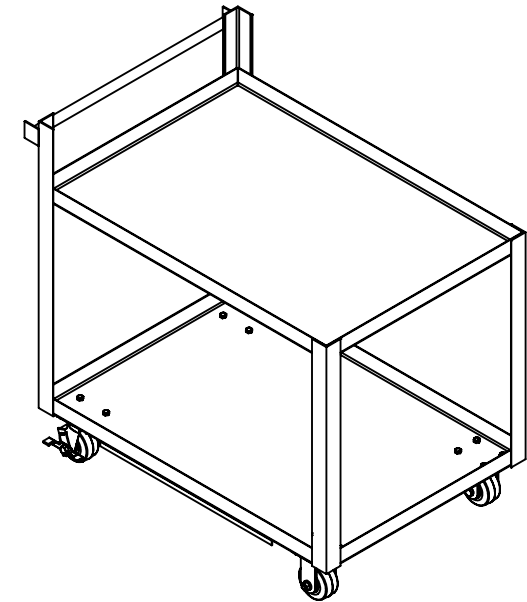
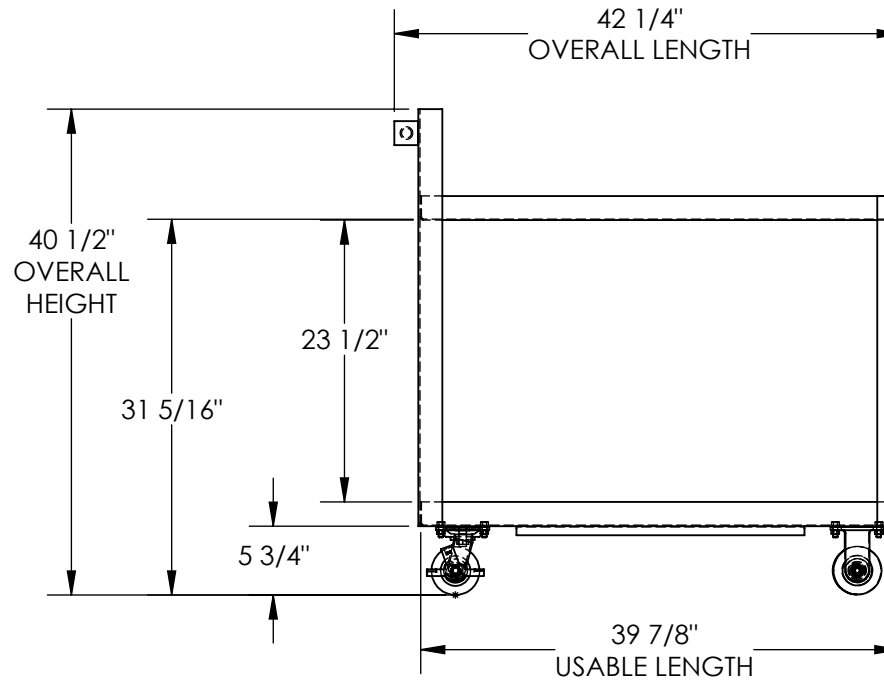
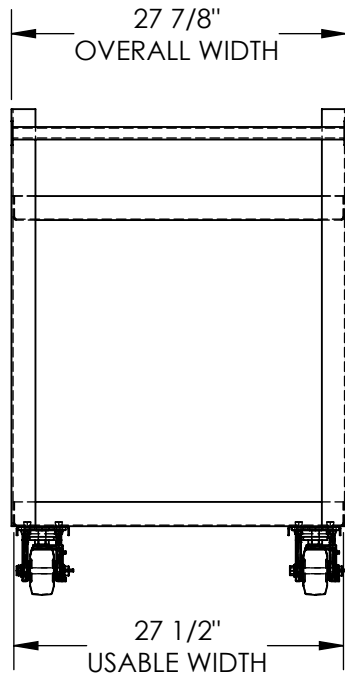

## STANDARD FEATURES

- MODEL NUMBER IS SCS2-2840
- OVERALL WIDTH IS 27 7/8"
- USABLE WIDTH IS 27 1/2"
- OVERALL LENGTH IS 42 1/4"
- USABLE LENGTH IS 39 7/8"
- OVERALL HEIGHT IS 40 1/2"
- MAX CAPACITY IS 1,000 lbs. (550 LBS. PER SHELF)
- STEEL FRAME CONSTRUCTION
- SHELF CLEARANCE 23 1/2"
- USABLE TOP SHELF HEIGHT IS 31 5/16"
- TOUGH BAKED IN POWDER COATED BLUE FINISH
- Ø 4" X 2" MOLD ON RUBBER
- 2 - SWIVEL CASTERS WITH BRAKE
- 2 - RIGID CASTERS

## SPECIAL FEATURES

NONE

DIMENSION TOLERANCE ± 1/4"

APPROVAL

I, THE UNDERSIGNED, AGREE THAT THE PRODUCT AS REPRESENTED SATISFIES DESIGN AND DIMENSION REQUIREMENTS. I ALSO ACKNOWLEDGE MY DUTY TO CONFIRM PRODUCT AND INSTALLATION COMPLIANCE WITH ALL APPLICABLE FEDERAL, STATE AND LOCAL REGULATIONS AND STANDARDS.

**UNITS REQUIRING APPROVAL DRAWINGS OR MODIFIED ARE NON-RETURNABLE**

As drawn       As marked

Signed: \_\_\_\_\_ Date: \_\_\_\_\_

Printed Name: \_\_\_\_\_

LEAD TIME WILL START UPON RECEIPT OF SIGNED APPROVAL DRAWING

DISTRIBUTOR'S NAME:		P.O.#
VESTIL MANUFACTURING		X
DRAWN BY: B.HORN		DATE: 07/17/14
REFERENCE: X		SCALE: 1:16
QUOTED LEAD TIME: X		QUOTE # X
		SALES: X
		FILE NAME: 16-007-107